



HAWIDO - REGULATING VALVES

Instruction manual for

**Pressure reducing valve
with motor-driven control valve
Type 1515**

ND40 - ND200



Keep this instruction manual at the location of the valve!

Example of rating plate

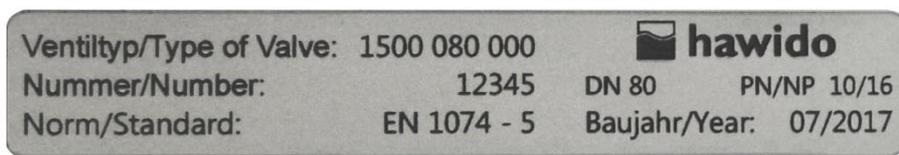

After the commissioning, enter the following data and make use of this additional information regarding the valve type, pressure and flow ratios when consulting the manufacturer or the supplier or asking them questions:

Serial number: DN PN:

Year of manufacture:.....

CONTENTS

A. DESCRIPTION	2
1. FUNCTION	2
2. GENERAL SAFETY INSTRUCTIONS	3
3. RECOMMENDED INSTALLATION	4
4. ELECTRICAL CONNECTIONS	5
4.1 CONNECTION GEAR MOTOR AND CONNECTOR PIN ASSIGNMENT	5
4.2 PRESSURE SENSOR CONNECTION	5
B. COMMISSIONING	6
1. FUNCTIONAL DIAGRAM (1515)	6
2. PREPARATORY WORK	6
3. VENTING	7
4. SETTING-UP	7
4.1 MANUAL SETTING OF THE TARGET PRESSURE (EMERGENCY ACTUATION)	8
5. SETTING THE REACTION SPEED	8
6. CHECKING FOR LEAKAGE	8
C. FAULT FINDING	9
D. PUTTING OUT OF SERVICE AND MAINTENANCE	10
1. PUTTING OUT OF SERVICE	10
2. MAINTENANCE AND SERVICE	10
2.1 GENERAL INFORMATION	10
2.2 ANNUAL FUNCTIONAL CHECKS	11
2.3 4 TO 5-YEAR MAINTENANCE	12
3. REPAIR KITS AND SPARE PARTS	13
3.1 BASE VALVE DN 40 TO DN 200 (DRAWING)	14
3.2 MAIN VALVE (PARTS LIST)	15
3.3 PRESSURE REDUCING STAINLESS STEEL CONTROL VALVE (DRAWING)	17
3.4 PRESSURE REDUCING STAINLESS STEEL CONTROL VALVE (PARTS LIST)	18
3.5 MOTOR DRIVE TO CONTROL VALVE (DRAWING)	19
3.6 MOTOR DRIVE TO CONTROL VALVE (PARTS LIST)	20
3.7 CONTROL LINE INDIVIDUAL PARTS AND ACCESSORIES	21
3.8 OPTICAL POSITION INDICATOR (DRAWING)	26
3.9 OPTICAL POSITION INDICATOR (PARTS LIST)	27
E. ANNEX	28
1. TORQUES	28
F. HAWLE IN EUROPE	29

A. Description

1. Function

The pressure reducing valve reduces a variable inlet pressure (p1) to a constant outlet pressure (p2). Fluctuating flow rate and inlet pressure have no effect on the outlet pressure controlled by the control valve. The outlet pressure (p2) is adjustable in the range from 1.5 to 12 bar (standard).

Different outlet pressures can be driven in conjunction with a control unit (provided by the customer) and the gear motor on the control valve (6).

Note:

The gear motor on the control valve is **not** intended for continuous controlling. It is used for setting the new target pressure. Pressure control is then assumed hydraulically/mechanically by the control valve (6).

Technical characteristics of the valve:

Medium:	Drinking water
Pressure stages:	PN 10 (from DN 200 Standard) PN16 (up to DN150 Standard) PN25
Flanges:	Connection dimensions according to DIN EN 1092 - 2
pressure gauge:	EN 837-1; Accuracy class 1.6
Main valve material:	EN-GJS-400-15
Temperature range:	2 – 40 °C

Technical characteristics of the pressure sensor:

Supply voltage	11 to 30VDC
Outlet signal	4 – 20mA
Temperature of the medium	-20°C - +100°C
Ambient temperature	-20°C – 85°C
Protection class	IP65
Process connection	½"

Technical characteristics of the motor:

Voltage:	24VDC
Nominal current:	0.3A
Max. inrush current:	1A
Power:	2.25W

2. General safety instructions

These instructions must be read through carefully and understood before starting the commissioning. Damage to property and injuries to persons could occur as a result of improper installation, commissioning, operation and maintenance.

The HAWIDO - regulating valve is designed for use in drinking water supply.
Other application media only after consultation with the manufacturer.

The technical regulations (e.g. SVGW, ÖVGW, DVGW...) and codes of practice (e.g. VDE, VDI ...), laws and standards are taken as a minimum standard, and must be adhered to and applied.

Work on electrical installations (e.g. installation of control systems, sensors, solenoid valves, etc.) may only be carried out by authorised and qualified personnel for this work.

In principle, the responsibility for the layout, the installation position, the installation and the commissioning of the fittings in the pipe work lies with the designer, the installation company and/or the operator. Design or installation errors can adversely affect the safe operation of the regulating valve, and can represent a significant risk. Please consult us in case of doubt.

3. Recommended installation

Before the installation of the fitting, the pipe lines must be carefully flushed through to prevent any foreign material, such as pieces of wood, stones etc., from entering the regulating valve.

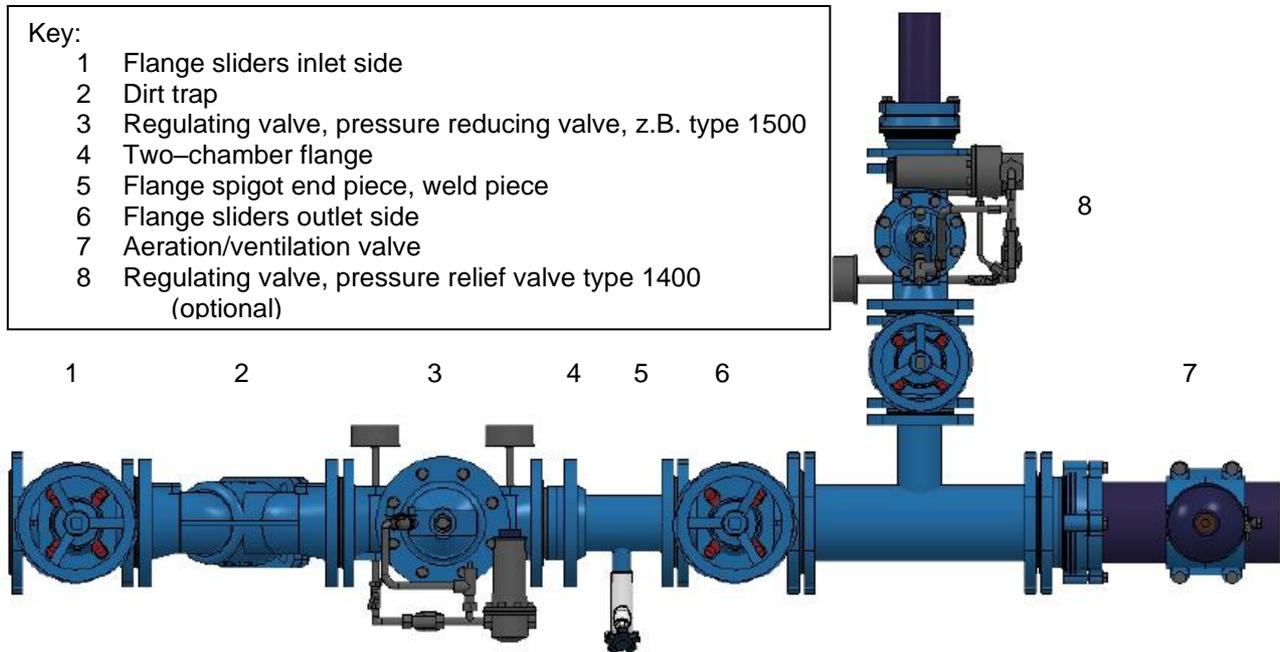

The HAWIDO must be installed horizontally with the valve cover upwards (other models available on request). We recommend that a gate valve and a dirt trap be fitted in front of the valve, as well as the mounting of an gate valve at the outlet.

During maintenance the valve must be taken out of service. A by-pass installation should be considered here in order to ensure the supply.

Depending on the system, the installation of a pressure relief valve type 1400 in the outlet after the pressure reducing valve should be considered.

Before the installation, check that no coarse foreign objects can penetrate into the HAWIDO.

Please contact us for other types of installation.

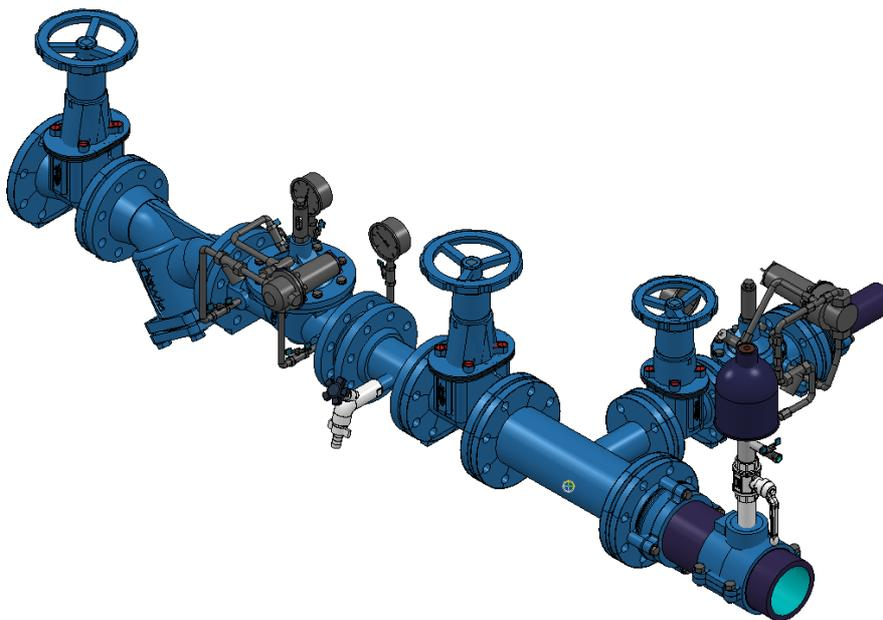

10.08.2017/plü

4. Electrical connections

4.1 Connection gear motor and connector pin assignment

1	bn	24VDC (brown)
2	ws	24VDC (white)
3	bl	Motor right-hand stop response (blue) → minimum outlet pressure (Spring in the pilot valve is unwound)
4	sw	Motor left-hand stop response (black) → maximum possible outlet pressure (Spring in the pilot valve is fully wound up)
5	gn	Earth (yellow/green)

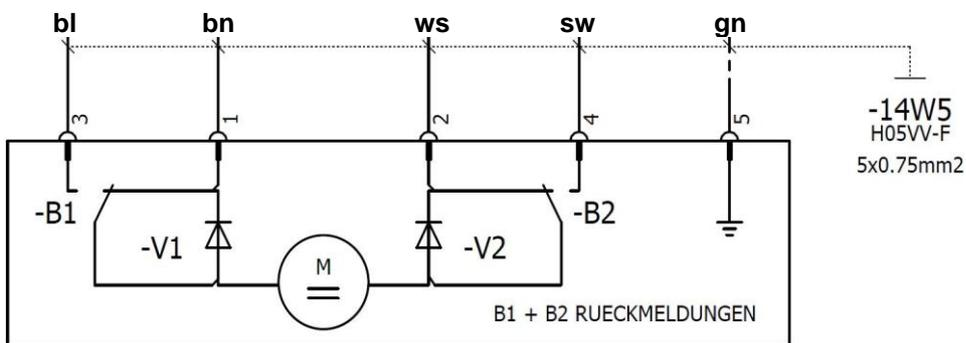
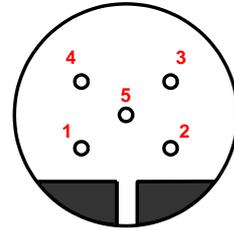

Outlet pressure (p_2) lower
→ = Motor clockwise rotation

Outlet pressure (p_2) raise
→ = Motor anti-clockwise rotation

Note: Please note chapter **B** Commissioning Item 4 and 4.1

4.2 Pressure sensor connection

The measuring pressure effectuates a slight deflection of the sensor diaphragm. The pressure-proportional change is measured and is available as a 4 – 20mA signal.

Connection diagram and connections:

1	(+)	brown
2	(-)	blue
3	not allocated	
PE	Measurement earth	green/yellow

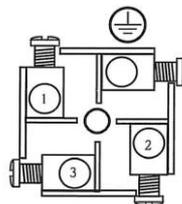

Pressure range:

0 to 1bar	1976 016 010
0 to 10bar	1976 016 100
0 to 16bar	1976 016 160
Other pressures on request.	

Note: Observe details on the rating plate.

B. Commissioning

1. Functional diagram (1515)

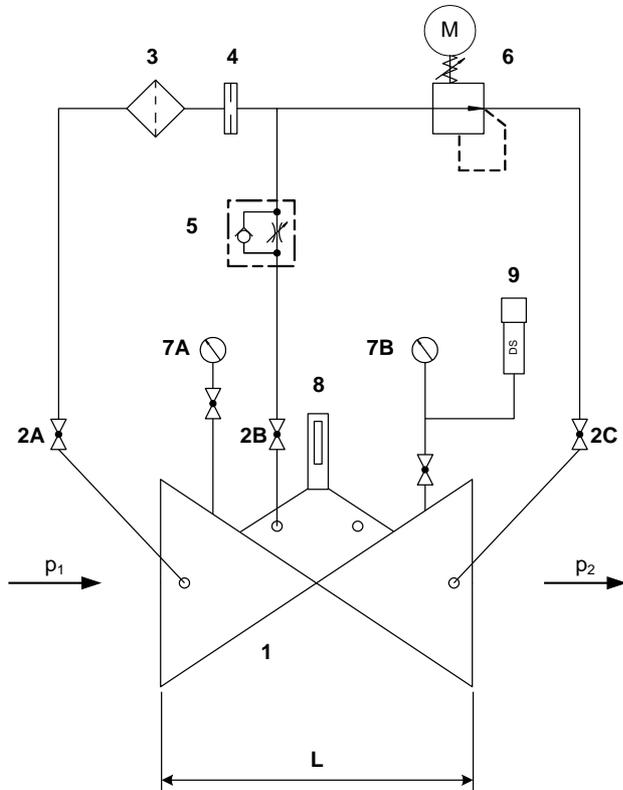

Components

- | | |
|---|------------------------------------------------------------------------|
| 1 | Main valve |
| 2 | Ball valve (A, B, C) |
| 3 | Filter |
| 4 | Orifice plate |
| 5 | One-way flow restrictor |
| 6 | Control valve with gear motor |
| 7 | Pressure gauge with ball valve (A, B) |
| 8 | Optical position indicator
Electrical position indicator (optional) |
| 9 | Pressure sensor |

2. Preparatory work

Before commissioning the valve, check that the gate valves on the inlet and outlet sides of the valve are **closed** and that the flange connections have been correctly tightened and sealed.

On the valve:

- Open ball valves (2A and 2B) and loosen the set screw lock nut on the one-way flow restrictor (5)
- Unscrew the adjusting screw on the one-way flow restrictor (5) by approximately 10 turns. (The line to the control chamber is open).
- Close the ball valve (2C)

On the control system (delivered by the customer)

- The control system is switched on and commissioned according to the customer's instructions.
- Set the control system to manual mode.
- The control valve must be completely relieved (gear motor clockwise rotation). The motor stops when the limit switch is reached. A brief reverse rotation via the control system allows the motor to move out of the internal limit stops (approx. 1 – 2 turns).

3. Venting

Procedure:

Slowly slightly open the inlet gate valve on the inlet side until water flows into the valve. The valve fills with water and closes. The inlet pressure increases. On the outlet side the pressure is between 0 and 0.5 bar.

- Slightly open the screw connection at the highest point and vent the valve.
- Vent the valve chambers well using the vent plug on the electrical position indicator.

When all the air has been expelled by venting the valve in the control line, re-tighten the loosened screw connection. Check that all the screw connections are properly sealed, and re-tighten if necessary.

Check: If the shut-off gate valve on the outlet side is slightly opened, the valve should close or remain closed. Afterwards once more close the shut-off valve on the outlet side.

If the valve does not close, the commissioning procedure must be repeated from the previous chapter. Particular care must then be taken to ensure that the upper valve chamber and control lines are properly vented.

Slowly open the inlet gate valve completely.

4. Setting-up

Prepare the valve according to the previous chapters. The slider on the inlet side is open and the slider on the outlet side is closed.

Procedure:

- Carry out the pre-setting of the flow control valve (5). Loosen the locknut. Completely screw in the setting screw with a screwdriver clockwise and then unscrew approx. 4 turns. Then retighten the locknut.
- **Slowly** open the ball valve (2C). The valve opens and fills the pipe work on the outlet side up to a pressure of approximately 0.4 bar. The valve then closes again.
- **Gradually and slowly** open the gate valve on the outlet side. The valve closes when the outlet line has filled and there is no water consumption. Depending on the piping system, this procedure can take several minutes.
- Create a normal water consumption for the nominal width (e.g. by opening a hydrant) so that the outlet pressure can be set by using the manual actuation of the control system.

Note:

Different pressures can be controlled with the **gear motor** on the **control valve** (6). Depending on the application and water system, this also leads to different flow rates. Manual setting of the pressure using the control system should be carried out with care and slowly. The hydraulic system should stabilise after each pressure adjustment. Check the pressure on the outlet side with the pressure gauge and the display on the control system.

Note:

The actuator on the control valve is **not** intended for continuous controlling. It is used for setting the new target pressure. Pressure control is then assumed by the hydraulically/mechanically controlled pilot valve (6).

Since the hydraulic water systems are subject to a certain inertia, the set value of the pilot valve should only be made in steps! This means, that after each *run time* for increasing or decreasing the pressure, a (*pause time*) must be allowed. These times are set as adjustable parameters in the control system.

Range:

Run time from 0.1 to 10 sec in 1/10 sec steps

Pause time from 1 to 60 sec in 1sec steps

4.1 Manual setting of the target pressure (emergency actuation)

If the the outlet pressure (p_2) must be adjusted after a power cut, this can be done using a 3 mm hexagon socket spanner on the motor.

Procedure:

- Loosen the blind cover (12) on the front of the motor (see chapter *Motor drive to control valve*) and actuate the spring over the motor with the hexagon socket spanner. However, due to the transmission ratio, many turns are necessary in order to adjust the pressure.
- **Caution:**
→ **Clockwise rotation** of the socket screw means **lowering** the outlet pressure → **anti-clockwise rotation** of the socket screw means **raising** the outlet pressure.

After adjustment screw the blind cover back on, otherwise the leak tightness to the motor is no longer guaranteed.

5. Setting the reaction speed

If the HAWIDO does not operate smoothly, or if pressure shocks occur in the supply network, this can be corrected by the adjustment of the flow control valve (5).

Procedure:

Loosen the locknut. Screw in the set screw clockwise with a screwdriver until the valve operates quietly. Then retighten the locknut.

Caution The setting screw must always remain at least 2 - 5 turns open, otherwise the valve will not re-open quickly enough after the closing sequence. A special setting is necessary for very high inlet pressures.

6. Checking for leakage

HAWIDO valves are tested at the factory for both leak tightness and function before delivery. When checking for leakage under operational conditions, particular attention must therefore be given to the seals of the flange connections, the control line and the central plug screw on the valve cover. Where necessary, ensure the seal by retightening the connections.

Notes:

C. Fault finding

Symptoms	Possible cause	Action
Valve does not open	One-way flow restrictor blocked	Replace, or unscrew the set screw several times until the valve functions properly
	One-way flow restrictor closed too far	Unscrew the set screw until the valve functions properly
Valve does not close	One-way flow restrictor blocked	Replace, or screw the set screw fully in and out several times and then re-set
	Filter in the control line blocked	Clean the filter
	Air in the control line / upper valve chamber	Vent
	Foreign matter in the main valve	Carry out service and remove any foreign matter
	Diaphragm defective	Carry out a service. Replace the diaphragm
	Valve spindle jammed by encrustation	Carry out service and remove any encrustation
Loud noise	Unfavourable operating conditions	Change pressure by approx. 0.1 to 0.2 bar. Slightly open or close the one-way flow restrictor. Contact the Hawle Customer Service department.
	Wrong valve size	Have the correct nominal size calculated (manufacturer)
Erratic operation	One-way flow restrictor incorrectly set	reset (according to chapter: <i>Setting the reaction speed</i>)
Original pressure values not reached	Pressure gauge faulty	Check or replace pressure gauge
	Changed operating conditions	Reset (see chapter: <i>Setting up</i>)
EWS coating damaged	Transportation damage, installation damage	Repair with Hawle two-component repair set for coatings

D. Putting out of service and maintenance

1. Putting out of service

Caution:

Work on electrical installations (e.g. installation of control systems, sensors, solenoid valves, etc.) may only be carried out by authorised and qualified personnel for this work.

The control system must first be decommissioned according to customer's instructions:

The operating valve must first be shut off hydraulically by proceeding as follows:

- **Slowly** close the gate valves before and after the valve
- **Slowly** close the ball valves (2A, 2B, 2C).
- **Pull out the plugs on the equipment** (affects: Pressure sensor, motor, electrical position indicator)

The valve has now been taken out of operation, and a service can be carried out.

2. Maintenance and service

2.1 General information

Through our many years of experience with diaphragm valves that are controlled by the flow medium, we know that our HAWIDOs normally function trouble-free for many years. Regular maintenance and functional checks are a precondition for this, however.

Under **normal** operating conditions, the following should be carried out:

- The valve should be checked for correct operation once a year (functional check)
- The dirt trap upstream of the valve and the filter in the control line should be cleaned once a year
- The inner working components should be checked and worn parts be replaced every four to five years (maintenance).

Under **unusual** operating conditions (e.g. with water that contains quantities of suspended matter, very high pressure reduction, small flow rates etc.), the functional checks and the service work should be carried out more frequently.

Maintenance sign:

Funktionskontrolle: jährlich	Wartung:	20xx
Contrôle fonctionnel: annuel	Maintenance:	
Prova di funzionamento: ogni anno	Mantenzione:	
Function check: annually	Maintenance:	

xx stands for the respective year.

2.2 Annual functional checks

Dirt trap (main line)

- Unscrew the lid
- Clean filter (use soft brushes, cloths or similar), or possibly replace filter.
- Install the filter and screw the lid back on

Filter (control line)

- Unscrew the lid of the filter
- Clean filter (use soft brushes, cloths or similar), or possibly replace filter.
- Re-install the filter and screw the filter lid back on

Checking the valve

- Remove optical position indicator or assembled accessories.
- Check the easy movement of the valve spindle by lifting and lowering with the spindle tool (article number 1199, see chapter “Control line individual parts and accessories”).
- Assemble optical position indicator or assembled accessories.

Putting back into service

- as described in the *Commissioning* paragraph

Functional check of the valve

Caution: In order to avoid pressure surges in the functional check described below, large flow rates must be throttled by **slowly** closing the gate valve in front of the valve.

- **Slowly** close the ball valve (2C); the valve must close.
- **Slowly** open the ball valve (2C); the valve must open.

Caution: Closing the ball valve too quickly can lead to pressure shocks and damage to the piping system.

Further option for the functional check: The function of the valve can be tested by manually adjusting the pressure. When lowering or raising the pressure, this adjustment must be visible on the pressure gauge.

2.3 4 to 5-year maintenance

Dirt trap (main line)

- Unscrew the lid
- Clean filter (use soft brushes, cloths or similar), or possibly replace filter.
- Install the filter and screw the lid back on

Filter (control line)

- Unscrew the lid of the filter
- Clean filter (use soft brushes, cloths or similar), or possibly replace filter.
- Re-install the filter and screw the filter lid back on

Base valve (see chapter: *Repair kits and spare parts*)

- Loosen the screw connections and remove the complete control line.
- Dismantle the optical position indicator or assembled accessories and replace the gaskets.
- Undo the screws of the valve cover and remove the cover.
- Visually inspect all inner components for wear, dirt and scaling
- Clean the inner components, the seat and the inner surfaces, including the cover
- Dismantle the spindle guide in the body, flush the body interior.
For valves DN 40 to DN 100 (from 2012 on) and DN 125 to DN 200 (from 2014 on) the spindle guide is dismantled from the inside. Here the thread of the spindle guide and the base valve must be **extremely clean**. Grease the thread thoroughly (e.g. Foodgrease Aqua, Art. no. 5292, see chapter "Control line individual parts and accessories").
- Replace the diaphragm, the O-ring and the seat seal.
- Grease the spindle guide area with a grease suitable for contact with food (e.g. Foodgrease Aqua). Check the easy movement of the spindle by lifting and lowering with the spindle lifting tool (article number 1199, see chapter "Control line individual parts and accessories").
- Reassemble the base valve (see table in the annex for torques). During the assembly, the easy movement of the spindle must be checked with the spindle lifting tool by lifting and lowering **several times**.

Disassembling the control valve (see chapter: *Repair kits and spare parts*)

- The pressure spring of the control valve is relieved (the gear motor is stopped up to the limit switch with the button on the control system).
- Loosen the body screws → **Caution**: the pressure screw and the pressure nut must not be adjusted, otherwise the internal end stops in the motor are no longer correct.
- Loosen the guide pins and the sealing plate
- Replace the diaphragm, the O-ring and, if necessary, the seal support
- Visually inspect the inner surfaces of the body, and clean if necessary, including the cover
- Reassemble the control valve (see table in the annex for torques).

Functional check of the one-way flow restrictor

- Undo the locknut
- Screw in the throttle screw, and then unscrew it as far as it goes
- Screw in again a few turns. This process must be easy and meet little resistance

Putting back into service

- According to *Commissioning* chapter

Functional check of the valve

Caution: In order to avoid pressure surges in the functional check described below, large flow rates must be **throttled** by **slowly** closing the inlet gate valve in front of the valve.

- **Slowly** close the ball valve (2C); the valve must close.
- **Slowly** open the ball valve (2C); the valve must open.

Following the functional check, the slider on the inlet side must be fully opened. Check whether the slider on the outlet side is fully open.

Caution: Closing the ball valve too quickly can lead to pressure shocks and damage to the piping system.

Further option for the functional check: The function of the valve can be tested by manually adjusting the pressure. When lowering or raising the pressure, this adjustment must be visible on the pressure gauge.

3. Repair kits and spare parts

Several replacement parts are required for the 4 or 5 - year service. These can be obtained as a repair kit for:

- the main valve
- the control valve
- the control line
- the optical position indicator

The article numbers can be found in the part lists and the lists of spare parts.

Caution:

When ordering replacement parts, always specify the valve type, serial number and year of construction!

Important:

Replacement parts made of EPDM (diaphragms, seals) and NBR (O-rings) must be stored in a dark place, protected from UV radiation!

Shelf-life when stored in the dark:

EPDM 8 years from date of manufacture

NBR 5 years from date of manufacture

3.1 Base valve DN 40 to DN 200 (drawing)

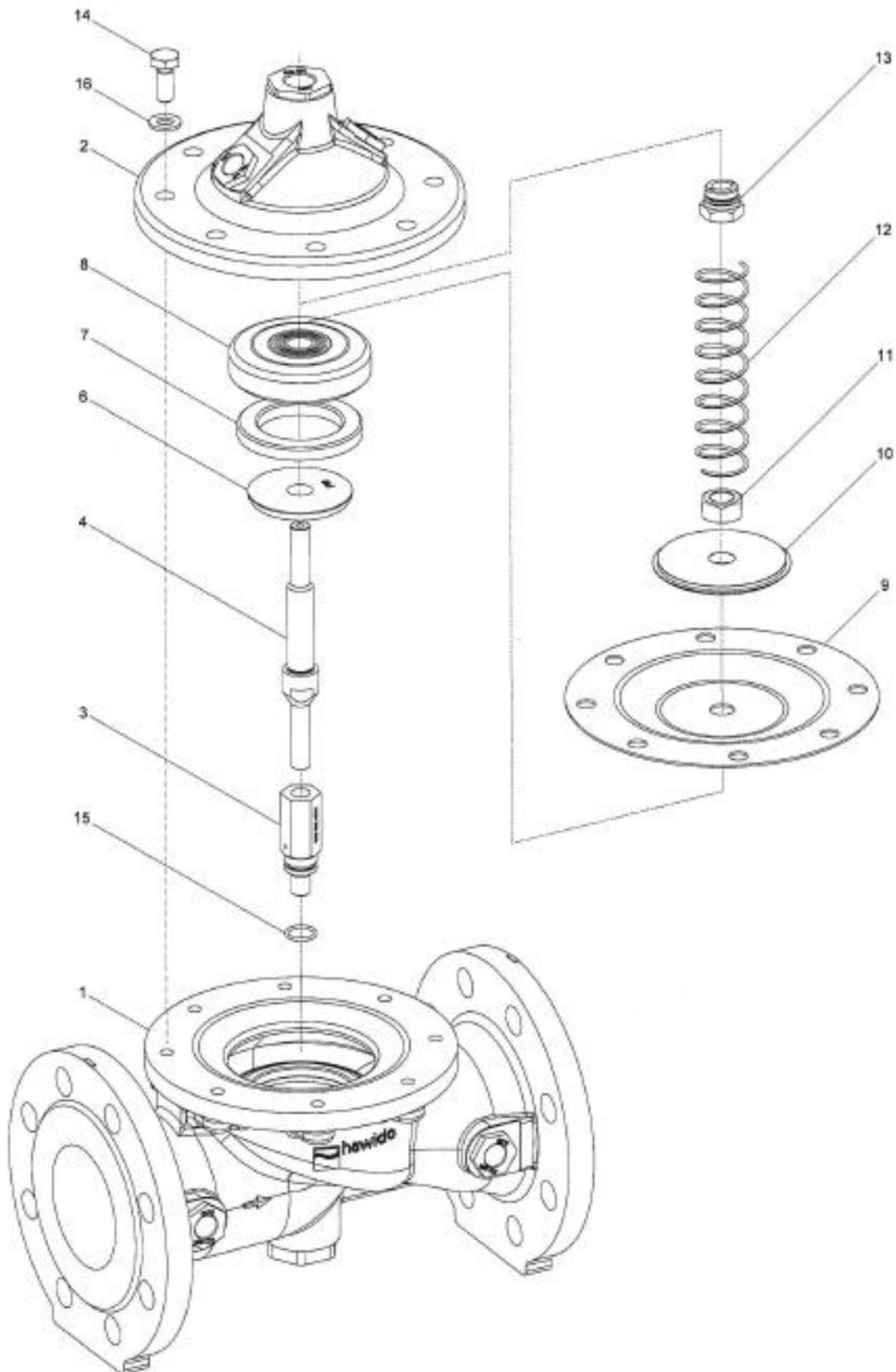

08.12.2011/plü

3.2 Main valve (Parts list)

Item.	Description	Material	Article number				
			DN 40	DN 50	DN 65	DN 80	DN 100
1	Body	GGG 40	1004 040 000	1004 050 000	1004 065 000	1004 080 000	1004 100 000
2	Valve cover	GGG 40	1014 050 000	1014 050 000	1014 065 000	1014 080 000	1014 100 000
3	Spindle guide cover	INOX	1024 900 000	1024 900 001	1024 900 002	1024 900 003	1024 900 004
4	Spindle	INOX	1026 050 000	1026 050 000	1026 065 000	1026 080 000	1026 100 000
5	Seat	INOX	*	*	*	*	*
6	Counter seat	INOX	1044 040 001	1044 050 001	1044 065 001	1044 080 001	1044 100 001
7	Seal	EPDM	1022 040 000	1022 050 000	1022 065 000	1022 080 000	1022 100 000
8	Seal carrier	INOX	1027 040 200	1027 050 200	1027 065 200	1027 080 200	1027 100 200
9	Diaphragm PN10/16	EPDM	1020 050 000	1020 050 000	1020 065 000	1020 080 000	1020 100 000
	Diaphragm PN25	EPDM	1020 050 000	1020 050 000	1021 065 000	1021 080 000	1021 100 000
10	Pressure disc	INOX	1047 050 000	1047 050 000	1047 065 000	1047 080 000	1047 100 000
11	Nut	INOX	0007 710 080	0007 710 080	0007 712 080	0007 716 080	0007 716 080
12	Spring	INOX	1049 050 000	1049 050 000	1049 065 000	1049 080 000	1049 100 000
	Spring for valves installed upright position	INOX	1050 050 000	1050 050 000	1050 065 000	1050 080 000	1050 100 000
13	Spindle guide cover	INOX	1042 900 000	1042 900 000	1042 900 001	1042 900 002	1042 900 002
14	Hexagonal screw	INOX	0006 608 020	0006 608 020	0006 610 025	0006 610 025	0006 612 025
15	O-ring	NBR	0180 012 020	0180 012 020	0180 012 020	0180 016 020	0180 016 020
16	Washer	INOX	0008 208 000	0008 208 000	0008 210 000	0008 210 000	0008 212 000
17	GSK-sticker		1099 900 000	1099 900 000	1099 900 000	1099 900 000	1099 900 000
18	Maintenance sticker		9691 0xx 000	9691 0xx 000	9691 0xx 000	9691 0xx 000	9691 0xx 000
	Main valve complete	PN10/16	1201 040 000	1201 050 000	1201 065 000	1201 080 000	1201 100 000
	Main valve complete	PN25	--	--	1201 065 025	1201 080 025	1201 100 025
	Repair kit for main valve with stainless steel connection, comprising item 7, 9, 15, 18	PN10/16	1080 040 000	1080 050 000	1080 065 000	1080 080 000	1080 100 000
		PN25	1080 040 000	1080 050 000	1081 065 000	1081 080 000	1081 100 000

Item	Description	Material	Article number			
			DN 125	DN 150	DN 200°	DN 200^
1	Body	GGG 40	1004 125 000	1004 151 000	1004 200 000	1004 200 016
2	Valve cover	GGG 40	1014 125 000	1014 151 000	1014 200 000	1014 200 000
3	Spindle guide cover	INOX	1024 900 005	1024 900 005	1024 900 006	1024 900 006
4	Spindle	INOX	1026 125 000	1026 151 000	1026 200 000	1026 200 000
5	Seat	INOX	*	*	*	*
6	Counter seat	INOX	1044 125 001	1044 150 001	1044 200 001	1044 200 001
7	Seal	EPDM	1022 125 150	1022 151 000	1022 200 000	1022 200 000
8	Seal carrier	INOX	1027 125 200	1027 151 200	1027 200 200	1027 200 200
9	Diaphragm PN10/16	EPDM	1020 125 150	1020 151 000	1020 200 000	1020 200 000
	Diaphragm PN25	CR	1051 125 150	1051 151 000	--	1034 200 000
10	Pressure disc	INOX	1047 125 150	1047 151 000	1047 200 000	1047 200 000
11	Nut	INOX	0007 720 080	0007 720 080	0007 724 080	0007 724 080
12	Spring	INOX	1049 125 150	1049 151 150	1049 200 000	1049 200 000
	Spring for valves installed upright position	INOX	1050 125 150	1050 151 000	1050 200 000	1050 200 000
13	Spindle guide cover	INOX	1042 900 003	1042 900 003	1042 900 004	1042 900 004
14	Hexagonal screw	INOX	0006 616 035	0006 616 035	0006 620 045	0006 620 045
15	O-ring	NBR	0180 018 020	0180 018 020	0180 021 020	0180 021 020
16	Washer	INOX	0008 216 000	0008 216 000	0008 220 000	0008 220 000
17	GSK-sticker		1099 900 000	1099 900 000	1099 900 000	1099 900 000
18	Maintenance sticker		9691 0xx 000	9691 0xx 000	9691 0xx 000	9691 0xx 000
21	Retaining bracket	INOX	--	--	1200 900 020	1200 900 020
	Main valve complete	PN10/16	1201 125 000	1201 151 000	1201 200 000	1201 200 016
	Main valve complete	PN25	1201 125 025	1201 151 025		1201 200 025
	Repair kit for main valve with stainless steel connection, comprising item 7, 9, 15, 18	PN10/16	1080 125 150	1080 151 000	1080 200 000	1080 200 000
		PN25	1081 125 150	1081 151 000		1081 200 000

° PN10
 ^ PN16
 * not interchangeable
 16.03.2018/plü

3.3 Pressure reducing stainless steel control valve (drawing)

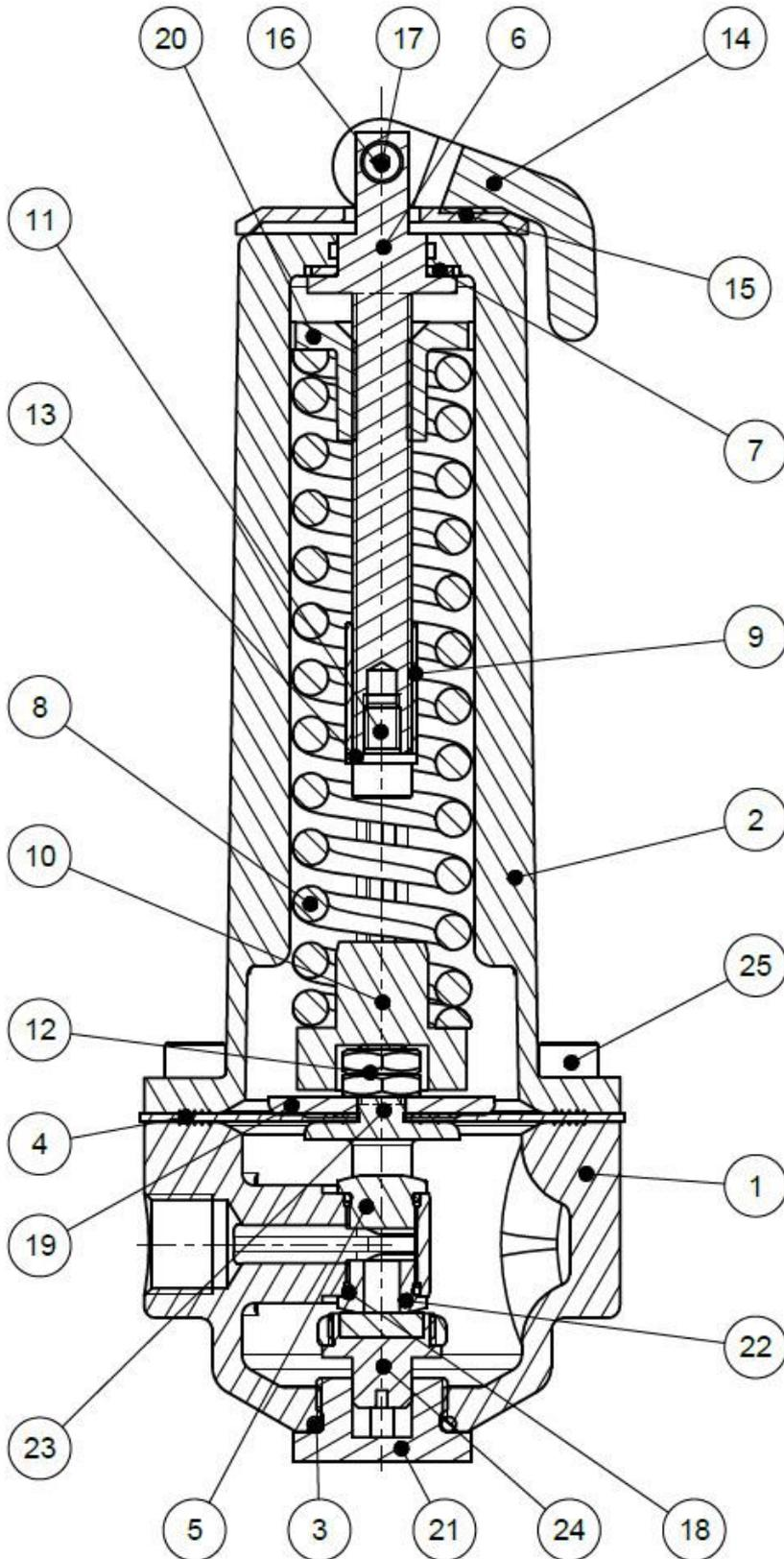

01.09.2017

3.4 Pressure reducing stainless steel control valve (parts list)

Item	Description	Material	Article number
			PN 16/25
1	Control casing	Stainless steel	1100 200 000
2	Cover	Stainless steel	1108 200 000
3	O-ring	NBR70	0180 020 025
4	Diaphragm DN3/8	EPDM (W270)	1121 000 000
5	Seat Compact Form 1.0, blank	Stainless steel	1117 200 000
6	Pressure screw	Stainless steel	1133 200 000
7	Fibre seal 15/25 x 1	Rubber	0132 024 015
8	Pressure spring	Stainless steel	1145 200 000
9	Spacer sleeve for spring	Stainless steel	1133 300 000
10	Spring guide	Stainless steel	1133 400 000
11	M6 x 10 Cap bolt	Stainless steel	0004 506 010
12	M8 x 0.5d Hexagon nut	Stainless steel	0007 208 050
13	U-washer	Stainless steel	0008 206 000
14	Clamping and adjusting lever	Kst – PA6.6	1135 000 001
15	Load washer for clamping lever	Kst – PA6.6	1135 000 010
16	Axle with IG to the clamping lever	Stainless steel	1135 000 011
17	M4 x 16 Cap bolt	Stainless steel	0004 804 016
18	O-ring	EPDM (W270)	0180 010 015
19	Pressure disc	Stainless steel	1129 012 000
20	Pressure collar nut	Bronze	1134 000 010
21	Guide pins (DRV/MBV)	STAINLESS STEEL	1137 000 000
22	Seat Compact Form 1.0, 6 mm	STAINLESS STEEL	1117 200 001
23	Yoke	STAINLESS STEEL	1136 000 002
24	DRV Sealing plate	STAINLESS STEEL/EPDM	1120 200 000
25	M6 x 16 Cap bolt	STAINLESS STEEL	0004 506 016
		REGULATING RANGE:	
	Complete control valve (standard)	1.5 – 12 bar	1900 001 000
	Complete control valve, identification	0.2 – 5 bar	1900 001 001
	Complete control valve, identification	10 – 22 bar	1900 001 002
	Repair kit consisting of: Items 3, 4, 18 (2 pcs.), 24		1180 000 020

01.09.2017/plü

3.5 Motor drive to control valve (drawing)

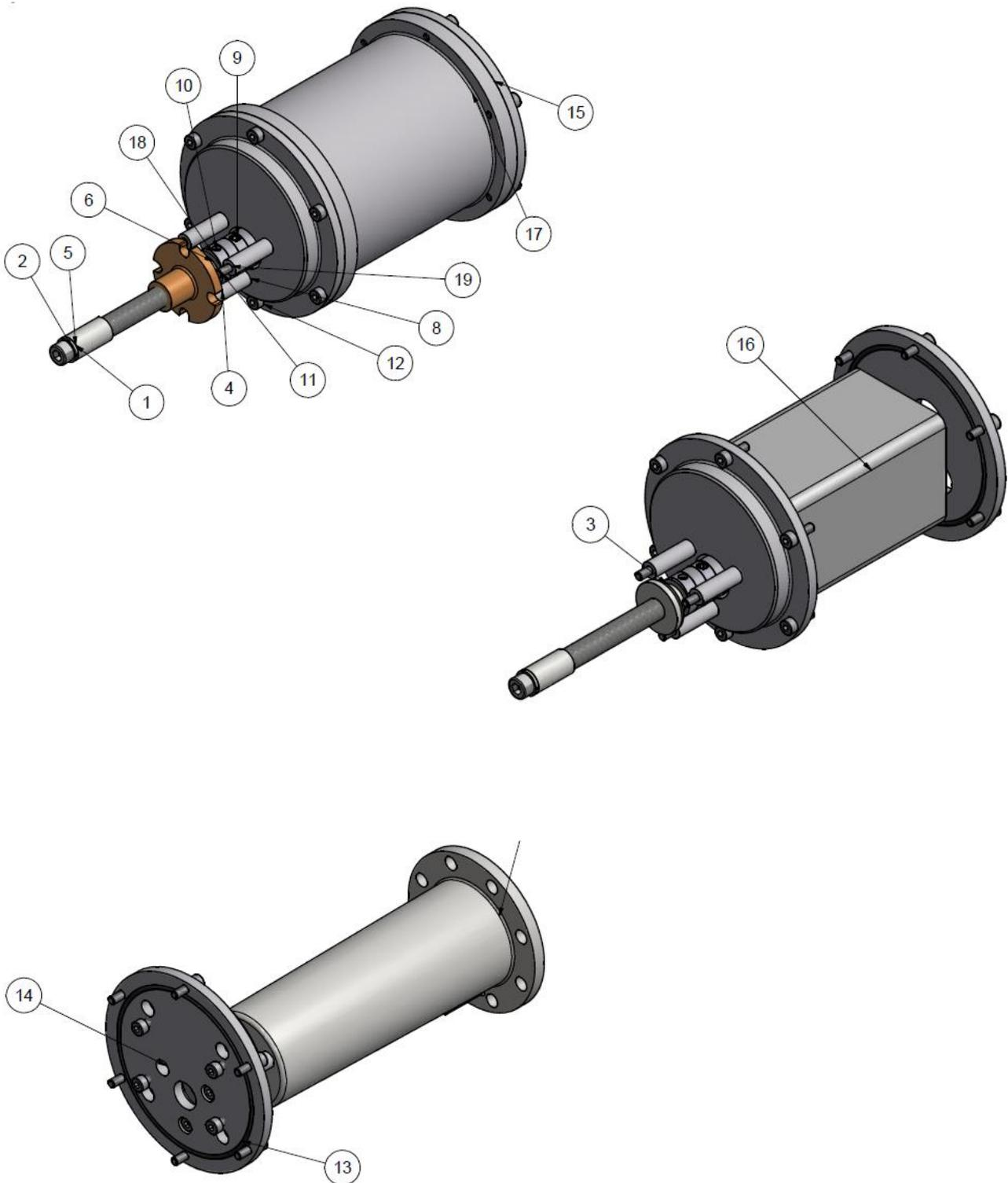

The pressure screw, pressure nut and the fibre washers are lubricated for a long duration and must not be dismantled. Dismantling the coupling and the pressure screw could possibly result in a new adjustment of the end stops.

Status August. 2015/plü

3.6 Motor drive to control valve (parts list)

Item	Description	Material	Article number
			PN 16/25
1	U-washer	Stainless steel	0008 206 000
2	M6 x 10 Cap screw	Stainless steel	0004 506 010
3	Fibre seal	Rubber	0132 024 015
4	Pressure nut for control valve	RG	1134 000 010
5	Spacer sleeve for spring	Stainless steel	1133 300 000
6	Pressure screw for gear motor	Stainless steel	1133 200 001
7	IX Cover	Stainless steel	1108 200 002
8	Adapter plate	Anticorodal -112	1970 900 101
9	M6 x 5 Threaded pin	Stainless steel	0002 206 005
10	M5 x 6 Threaded pin	Stainless steel	0001 005 006
11	M4 x 40 Cap screw	Stainless steel	0004 604 040
12	M4 x 12 Cap screw	Stainless steel	0004 504 012
13	O-ring	NBR	0180 082 020
14	Compound seal	Steel	1970 900 105
15	Cover plate	Anticorodal -112	1970 900 102
16	Gear motor without body		1970 900 100
17	Protection pipe with flange	Anticorodal -112	1970 900 103
18	Coupling	Stainless steel	1970 900 003
19	Spacer sleeve	Anticorodal -112	1970 900 104
	Gear motor complete including cover		1970 000 002

Status Aug.. 2015/plü

3.7 Control line individual parts and accessories

Master number Designation	Picture	Size possibly further sizes available	Art. number
0130 Compound seal		stainless steel/NBR 3/8" stainless steel/NBR 1/2" stainless steel/NBR 3/4" Steel/NBR 1"	0130 012 000 0130 016 000 0130 025 000 0130 032 000
0273 Individual parts		Fitting connection (consisting of: connector nut and clamping ring) DN 12 stainless steel	0273 012 000
0275 Support sleeve		stainless steel d4 – 6 stainless steel d12 – 9 stainless steel d12 – 10	0275 006 004 0275 012 009 0275 012 010
0283 Clamping ring		d6 stainless steel d12 stainless steel d18 stainless steel d8 - 6 stainless steel	0283 006 000 0283 012 000 0283 018 000 0283 008 006
0284 Orifice plate (Old orifice plate number 0281.		d12 stainless steel Ø 0.6 mm d12 stainless steel Ø 0.9 mm d12 stainless steel Ø 1.2 mm d12 stainless steel Ø 1.5 mm d12 stainless steel Ø 1.9 mm d12 stainless steel Ø 2.4 mm d12 stainless steel Ø 3.1 mm d18 stainless steel Ø 3.5 mm d18 stainless steel Ø 4.0 mm	0284 006 000 0284 009 000 0284 012 000 0284 015 000 0284 019 000 0284 024 000 0284 031 000 0284 035 010 0284 040 010
0311 Screw connection with screw-in nipple		d 12 - 3/8" stainless steel d 12 - 1/2" stainless steel d 6 - 1/8" stainless steel d 6 - 1/4" stainless steel d 6 - 3/8" stainless steel d18 – 1/2" stainless steel	0311 012 012 0311 012 016 0311 006 004 0311 006 008 0311 006 012 0311 018 016
0323 Straight fitting		d 6 stainless steel d 12 stainless steel	0323 006 000 0323 012 000
0324 Straight socket end fitting		d12 - 3/8"	0324 012 012
0351 Reduction fitting		d6 – d12 stainless steel	0351 012 006
0361 Transition sleeve		d 10 - 3/8" stainless steel d 12 - 3/8" stainless steel d 12 - 1/2" stainless steel d 18 – 1/2" stainless steel	0361 010 012 0361 012 012 0361 012 016 0361 018 016
0371 Reduction nipple		IG d 12 – AG 3/8" stainless steel	0371 012 012

0401 Sleeve		3/8" stainless steel 1/2" stainless steel 3/4" stainless steel 1" stainless steel	0401 012 000 0401 016 000 0401 025 000 0401 032 000
0411 Adjuster nipple		DN 6 - 1/8" stainless steel DN12 - 3/8" stainless steel	0411 006 004 0411 012 012
0431 Screw-in elbow		DN 6 - 1/8" stainless steel DN6 - 1/4" stainless steel DN12 - 3/8" stainless steel DN18 - 1/2" stainless steel	0431 006 004 0431 006 008 0431 012 012 0431 018 016
0431 Screw-in elbow with vent		DN 123/8" Stainless steel	0431 012 013
0451 Angled fitting		DN6 stainless steel DN12 stainless steel DN18 stainless steel	0451 006 000 0451 012 000 0451 018 000
0452 90° Adjuster elbow		DN12	0452 012 000
0455 Connector elbow		IG 3/8" stainless steel IG 1/2" stainless steel IG 3/4" stainless steel IG 1" stainless steel	0455 012 000 0455 016 000 0455 025 000 0455 032 000
0456 Connector elbow		IG 3/8" - AG 3/8" stainless steel IG 1/2" - AG 1/2" stainless steel IG 3/4" - AG 3/4" stainless steel IG 1" - AG 1" stainless steel	0456 012 000 0456 016 000 0456 025 000 0456 032 000
0461 T-piece		d6 stainless steel d12 stainless steel d12 - 6 - 12 stainless steel d18 stainless steel	0461 006 000 0461 012 000 0461 012 006 0461 018 000
0510 Plug		AG 3/8" conical stainless steel AG 1/2" conical stainless steel	0510 012 000 0510 016 000
0511 Vent plug, lock screw		AG 1/2" stainless steel AG 3/4" stainless steel AG 1" stainless steel with hexagon socket	0511 016 000 0511 025 000 0511 032 001
0520 hexagon double nipple		d 1/8" stainless steel d 1/4" stainless steel d 3/8" stainless steel d 1/2" stainless steel d 3/4" stainless steel	0520 004 000 0520 008 000 0520 012 000 0520 016 000 0520 025 000
0541 Ball valve		DN 3/8" stainless steel DN 1/2" stainless steel DN 3/4" stainless steel	0541 012 001 0541 016 000 0541 016 010

<p>0545 Stainless steel dirt filter</p>		<p>Stainless steel Y-filter IG 3/8" Individual parts: Dirt filter stainless steel Plug, complete for Y-filter, stainless steel Large seal for Y-filter, POM Small O-ring for plug</p>	<p>0545 112 002 0545 900 051 0545 112 010 0545 112 011 0545 112 012 0545 116 000</p>
<p>0549 Flow control valve & check valve</p>		<p>DN 3/8" Check valve brass nickel-plated stainless steel IG 3/8" type B d 12 with long spindle</p>	<p>0549 000 002 0549 000 005</p>
<p>0570 non-return valve</p>		<p>3/8" brass(max. 40 bar) 1/2" brass(max. 40 bar)</p>	<p>0570 012 045 0570 016 045</p>
<p>0600 pressure gauge</p>		<p>AG 3/8" 0 - 6 bar AG 3/8" 0 - 10 bar AG 3/8" 0 - 16 bar AG 3/8" 0 - 25 bar AG 3/8" 0 - 40 bar AG 3/8" 0 - 60 bar</p>	<p>0600 012 006 0600 012 010 0600 012 016 0600 012 025 0600 012 040 0600 012 060</p>
<p>0610 Solenoid valves</p>		<p>Solenoid valve, normally open 2/2-way valve (for 1795/96) 122K84</p> <p>Solenoid valve, normally closed 2/2 way valve (for 1795/96) E121K04</p> <p>Solenoid valve, normally open 3/2 way valve (for 1703 to DN 100 1603, 1706 PN 16 all nominal sizes) 132K04</p> <p>Solenoid valve normally closed 3/2 way valve (for 1704 to DN 100, 1604) E131K04</p> <p>Solenoid valve normally open 2/2 way valve (for 1704 from DN 125 1304, 1404, 1504) (old: E322 H73 06)</p> <p>Solenoid valve normally closed 2/2 way valve, with manual override (For 1703 from DN 125,1303, 1403, 1503, 1706 PN 25 from DN 125) (old: E321 (H13)</p> <p>Solenoid valve universal 3/2 way valve (for 1706 PN 25 to DN 100)</p> <p>*****</p> <p>Replacement part. Diaphragm, for MV type 0610 510 001 and 0610 510 002</p> <p>Replacement part set for MV type 0610 510 001 Consisting of: Diaphragm, Armature guide tube, armature and seals</p>	<p>0610 122 084</p> <p>0610 121 004</p> <p>0610 132 004</p> <p>0610 131 004</p> <p>0610 510 002</p> <p>0610 510 001</p> <p>0610 133 005</p> <p>*****</p> <p>0610 590 001</p> <p>0610 590 002</p>

<p>0620, 0621 Coils</p>		<p>AC coils with voltage indication</p> <p>DC coils with voltage indication</p>	<p>0620 xxx xxx</p> <p>0621 xxx xxx</p>
<p>0630 Appliance socket</p>		<p>Appliance socket for electromagnet</p>	<p>0630 000 000</p>
<p>0653 Connector modules</p>		<p>Connector modules for solenoid valves Type LBV 24 DC 8S, incl. 2m cable</p> <p>Connector modules for solenoid valves Type LBV IN: 48-230VAC/DC OUT: 48VDC incl. 2m cable 3-wire (Only to be used for 48VDC coils)</p>	<p>0653 024 008</p> <p>0653 230 000</p>
<p>0670 Overcut</p>		<p>AG 3/8" IG 1/8" stainless steel AG 3/8" IG 1/4" stainless steel AG 1/2" IG 3/8" stainless steel AG 3/4" IG 3/8" stainless steel AG 1" IG 1/8" stainless steel AG 1" IG 1/2" stainless steel</p>	<p>0670 012 004 0670 012 008 0670 016 012 0670 025 012 0670 032 012 0670 032 016</p>
<p>0671 Sleeve nipple reduced</p>		<p>IG 1/2" AG 3/8" IG 1" AG 3/8" IG 1" AG 1/2" IG 1" AG 3/4"</p>	<p>0671 016 012 0671 032 012 0671 032 016 0671 032 025</p>
<p>0680 Barrel nipple</p>		<p>AG 3/8" L = 30 mm stainless steel AG 3/8" L = 40 mm stainless steel AG 3/8" L = 50 mm stainless steel AG 3/8" L = 60 mm stainless steel AG 3/8" L = 70 mm stainless steel AG 3/8" L = 80 mm stainless steel AG 3/8" L = 110 mm stainless steel AG 1/2" L = xxx mm stainless steel</p>	<p>0680 012 030 0680 012 040 0680 012 050 0680 012 060 0680 012 070 0680 012 080 0680 012 110 0680 016 xxx</p>
<p>0690 Adapting nipple</p>		<p>AG 3/8" - 1/8" AG 3/8" - 1/4" AG 1/2" - 3/8" AG 3/4" - 3/8" AG 1" - 3/8" AG 1" - 1/2"</p>	<p>0690 012 004 0690 012 008 0690 016 012 0690 025 012 0690 032 012 0690 032 016</p>
<p>0711 T-fitting</p>		<p>IG 3/8" level stainless steel IG 1/2" level stainless steel IG 3/4" level stainless steel IG 1" level stainless steel</p>	<p>0711 012 000 0711 016 000 0711 025 000 0711 032 000</p>
<p>0730 Seamless tube</p>		<p>d6 x 1mm stainless steel d12 x 1.5 mm stainless steel d15 x 1.5 mm stainless steel d18 x 1.5 mm stainless steel</p>	<p>0730 006 010 0730 012 015 0730 015 015 0730 018 015</p>

<p>1188 Rep. Set Control line</p>		<p>From serial number 14252 (January 2003) DN40 to 100 DN125 to 300</p> <p>From approx. serial number 25915 (June 2014, Filter type B (0545 112 002) DN40 to 100 DN125 to 200</p>	<p>1188 065 100 1188 125 300</p> <p>1188 000 000 1188 000 001</p>
<p>SA.0 PA-tube</p>		<p>Polyamide tube OD 6 mm, ID 4 mm Polyamide tube OD 12 mm, ID 9 mm</p>	<p>SA.0 000 060 SA.0 000 290</p>

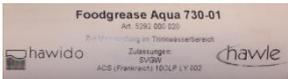
Tools and accessories			
<p>1199 Spindle lifting tool</p>		<p>M5 M6</p>	<p>1199 000 000 1199 000 010</p>
<p>1199 Spanner for sealing plate</p>		<p>Spanner for assembling and dismantling the sealing plate from the DRV pilot valve</p>	<p>1199 000 020</p>
<p>1199 Socket spanner attachment</p>		<p>Socket spanner attachment for flow control valve</p>	<p>1199 000 030</p>
<p>1199 Socket spanner</p>		<p>Socket spanner for flow control valve</p>	<p>1199 000 040</p>
<p>5292 Grease</p>		<p>Foodgrease Aqua Tube with 175g</p>	<p>5292 000 020</p>

02.02.2018/plü

3.8 Optical position indicator (Drawing)

DN 40 – DN 100

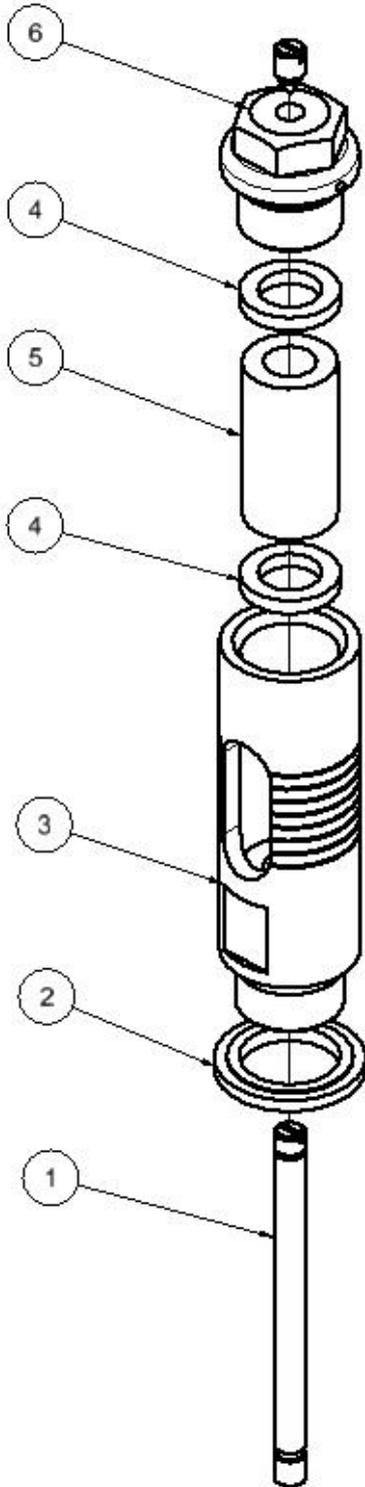

DN 125 – DN 300

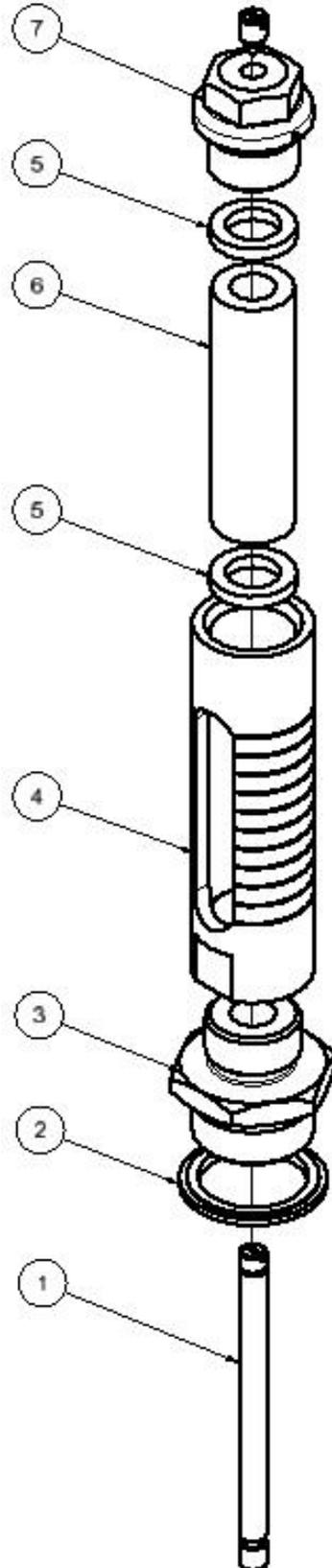

12.03.2014/plü

3.9 Optical position indicator (Parts list)

Item	Description	Material	Article number				
			DN 40	DN 50	DN 65	DN 80	DN 100
1	Indicator pin	Stainless steel	1992 000 050	1992 000 050	1992 000 080	1992 000 080	1992 000 100
2	Compound seal ½"	Stainless steel NBR	0130 016 000	0130 016 000	0130 016 000	0130 016 000	0130 016 000
3	Indicator body	Stainless steel	1994 000 010	1994 000 010	1994 000 010	1994 000 010	1994 000 010
4	Seal	EPDM70	1992 900 030	1992 900 030	1992 900 030	1992 900 030	1992 900 030
5	Sight tube	Glass	1993 050 100	1993 050 100	1993 050 100	1993 050 100	1993 050 100
6	Plug ½"	Stainless steel	0511 016 000	0511 016 000	0511 016 000	0511 016 000	0511 016 000
	Optical position indicator, complete		1995 000 050	1995 000 050	1995 000 080	1995 000 080	1995 000 100
	Repair kit consisting of Items 2 and 4		1996 000 000	1996 000 000	1996 000 000	1996 000 000	1996 000 000

Item	Description	Material	Article number				
			DN 125	DN 150	DN 200	DN 250	DN 300
1	Indicator pin	Stainless steel	1992 000 125	1992 000 150	1992 000 200	1992 000 250	1992 000 300
2	Compound seal ¾"	Stainless steel NBR	0130 025 000	0130 025 000	0130 025 000		
	Compound seal 1"	Steel/NBR				0130 032 000	0130 032 000
3	Adapting nipple	Stainless steel	1992 900 020	1992 900 020	1992 900 020	1992 900 025	1992 900 025
4	Indicator body	Stainless steel	1994 000 020	1994 000 020	1994 000 020	1994 000 020	1994 000 030
5	Seal	EPDM70	1992 900 030	1992 900 030	1992 900 030	1992 900 030	1992 900 030
6	Sight tube	Glass	1993 125 250	1993 125 250	1993 125 250	1993 125 250	1993 300 000
7	Plug ½"	Stainless steel	0511 016 000	0511 016 000	0511 016 000	0511 016 000	0511 016 000
	Optical position indicator, complete		1995 000 125	1995 000 150	1995 000 200	1995 000 250	1995 000 300
	Repair kit consisting of Items 2 and 5		1996 000 010	1996 000 010	1996 000 010	1996 000 020	1996 000 020

12.03.2014/plü

E. Annex

1. Torques

When assembling the base valve and the control valves all **bolts** are checked with a torque spanner according to the following list. Lightly grease the bolts before assembling!

Base valves	Nominal size DN	Hex bolt M	Strength Class ¹⁾	Tightening torque	
				Target	Max. ²⁾
	40 - 50	M 8	A4/80	22 Nm	25 Nm
	65 - 80	M 10		47 Nm	50 Nm
	100	M 12		84 Nm	87 Nm
	125 - 150	M 16		172 Nm	216 Nm
	200	M 20		285 Nm	423 Nm
	250	M 20		285 Nm	423 Nm
300	M 20	380 Nm		423 Nm	

Control valves	Type	Socket M	Strength Class ¹⁾	Tightening torque	
				Target	Max.
	DRV / DAV	M 6	A2 / A4 / 70	8 Nm	8.5 Nm
	MBV / RBS				
Control valve	Hex screw M	Strength class	Tightening torque		
NAZ	M 6	A2 / A4 / 70	8 Nm	8.5 Nm	

(Not for new applications)

Base valves	Nominal size DN	Hex screw M	Strength Class ¹⁾	Tightening torque	
				Target	Max.
	40 - 50	M 8	A2/70	17 Nm	19 Nm
	65	M 10		33 Nm	36 Nm
	80	M 10		40 Nm	40 Nm
	100	M 12		70 Nm	72 Nm
	125 - 150	M 16		172 Nm	172 Nm
	200	M 20		280 Nm	285 Nm
	250	M 20		280 Nm	285 Nm
300	M 20	235 Nm		240 Nm	

Caution: ¹⁾ = Note designation on screw head A2 – 70 or A4 – 80!

²⁾ = Maximum permitted torque according to strength analysis

Bolts according to SN EN ISO 4014 and SN EN ISO 4017

As at: FO 0065, Rev. 12 / 19.12.2017

F. Hawle in Europe

Addresses:

Hawle Armaturen AG
Hawlestrasse 1
CH-8370 Sirmach
www.hawle.ch

telephone +41 (0)71 969 44 22
fax +41 (0)71 969 44 11

Hawle Armaturen GmbH
Liegnitzer Strasse 6
D-83395 Freilassing
www.hawle.de

telephone +49 (0)8654 63 03 - 0
fax +49 (0)8654 63 03 60

E. Hawle Armaturenwerke GmbH
Wagrainerstr. 13
A-4840 Vöcklabruck
www.hawle.at

telephone +43 (0)76 72/72 576 0
fax +43 (0)76 72 78 464

Hawle Kft
Dobogókői út 5
H-2000 Szentendre
www.hawle.hu

telephone +36 (0) 26 501 501
fax +36 (0) 26 501 502

Hawle Armatury spol. s r.o.
Ricanská 375
CZ-25242 Jesenice u.Prahy
www.hawle.cz

telephone +420 (0)2 410 03 111
fax +420 (0)2 41 00 33 33

Hawle Spółka zo.o
ul. Piaskowa 9
PL-62-028 Kozięglowy
www.hawle.pl

telephone +48 (0)61 811 14 00
fax +48 (0)61 811 14 27

Hawle s.r.o.
Pezinská c.30
SK-903 01 Senec
www.hawle.sk

telephone +421 (0)2 45 92 21 87
fax +421 (0)2 45 92 21 88

S.C. Hawle S.R.L.
Calea Sagalului 104
RO-300516 Timisoara
www.hawle.ro

telephone +40 268 47 78 81
fax +40 356 80 06 68

Hawle Armaturen EOOD
Prof. Ivan Georgov Str. 1a / Fl. 2
BG-1220 Sofia
www.hawle.bg

telephone +359 (0)2 931 12 77
Fax +359 2 931 04 36

Partners / Contact addresses:

19.12.2008-1/plü