





HAWIDO - REGULATING VALVES

Instruction for

**Analogue position indicator
Type 1960/61**



Keep this instruction manual at the location of the valve!

Example of rating plate

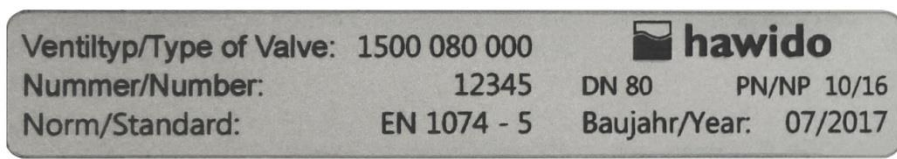

After the commissioning, enter the following data and make use of this additional information regarding the valve type, pressure and flow ratios when consulting the manufacturer or the supplier or asking them questions:

Serial number: DN PN:

Year of manufacture:.....

CONTENTS

A. FUNCTION	2
1. PRINCIPLE OF OPERATION	2
2. GENERAL SAFETY INSTRUCTIONS	2
B. COMMISSIONING	3
1. FUNCTIONAL DIAGRAM (1960/61)	3
2. PREPARATION AND COMMISSIONING OF THE VALVE	3
C. SENSOR	4
1. SENSOR 4 – 20MA (ART. NO.. 1960)	4
2. SETTING THE OPENING LIMITER (OPTIONAL)	5
3. SETTING THE SENSOR	6
4. TROUBLESHOOTING	7
D. MAINTENANCE AND REPLACEMENT PARTS	8
1. MAINTENANCE	8
2. SPARE PARTS	8
2.1 ANALOGUE POSITION INDICATOR (DRAWING)	8
2.2 ANALOGUE POSITION INDICATOR (PARTS LIST)	9
E. HAWLE IN EUROPE	11

A. Function

1. Principle of operation

Please refer to the drawing on the next page.

The exact position (analogue position) of the valve spindle (valve opening) is indicated with electrical signals from the sensor (11). The sensor is teachable

Technical features:

Medium:	Drinking and process water
Pressure stages:	Range of operation up to PN25
Material	Stainless steel
Permitted ambient temperature:	2 – 40 °C

2. General safety instructions

The instructions for the regulating valve must be read through carefully and understood before starting the commissioning. Damage to property and injuries to persons could occur as a result of improper installation, commissioning, operation and maintenance.

The analogue position indicator is intended exclusively for use on HAWIDO regulating valves. Before connecting the sensor, power must be removed from the system.

Work on electrical installations (e.g. installation of electrical position indicators, solenoid valves, etc.) may only be carried out by personnel authorised for this work.

In principle, the responsibility for the layout, the installation position, the installation and the commissioning of the fittings in the pipe work lies with the designer, the installation company and/or the operator. Design or installation errors can adversely affect the safe operation of the regulating valve, and can represent a significant risk. Please consult us in case of doubt.

B. Commissioning

1. Functional diagram (1960/61)

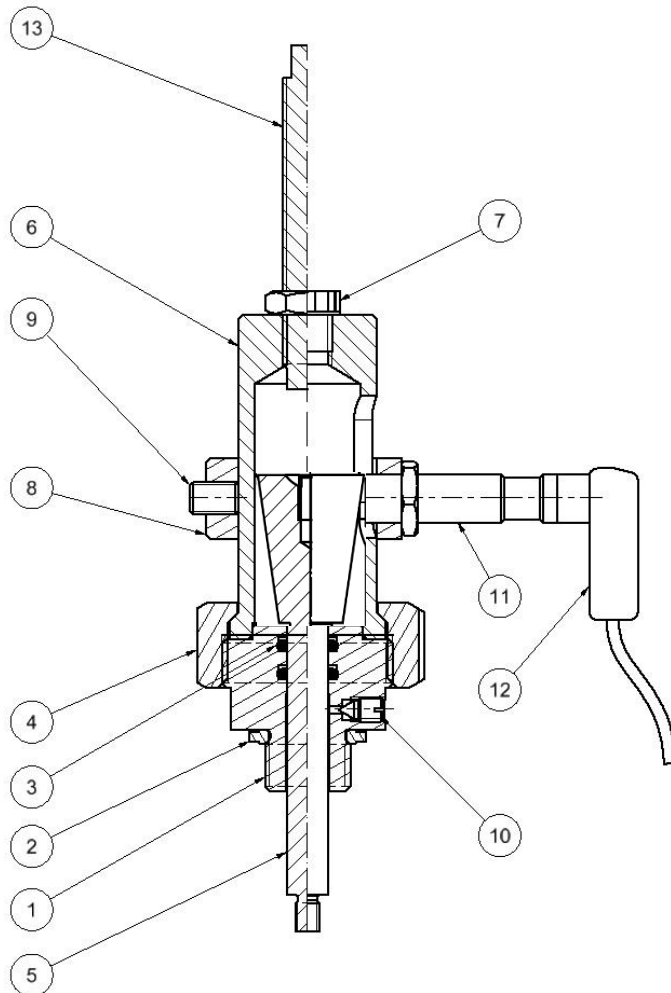

Main components

- 1 Guide
- 4 Union nut
- 5 Display spindle complete
- 6 Housing
- 8 Retaining collar
- 9 Threaded pin
- 10 Vent screw
- 11 Sensor 4 – 20mA: Art. no.: 1961 903 011
Sensor 0 – 10V: Art. no.: 1961 903 021
- 12 Cable box angled with 5 m cable
- 13 opening limiter DN1½" to DN200 (Option)

2. Preparation and commissioning of the valve

The analogue position indicator on the valve is pre-assembled at the factory. The regulating valve is correctly and professionally installed. The electrical connections have been made and connected.

In case the position indicator is subsequently mounted / retrofitted, please contact the manufacturer.

Carry out commissioning of the valve according to separate instructions. **Please note:** Venting of the vent takes place by slightly opening the threaded pin (10). After venting, re-tighten the threaded pin (10).

C. Sensor

1. Sensor 4 – 20mA (Art. no.. 1960)

Technical data:

Measuring distance	0 ... 6 mm
Sensitivity	2.67 mA/mm
Operating voltage range	8 ... 36 VDC
Power consumption max.	15 mA
Output circuit	Power output
Output signal	4 ... 20 mA
Housing material	Nickel-plated brass
Operating temperature	-25° ... 75°C
Protection class	IP 67
Tightening torque max.	15 Nm

Connection diagram:

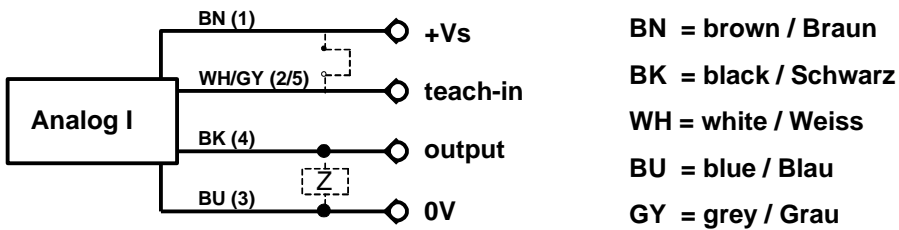

Connector pin assignment:

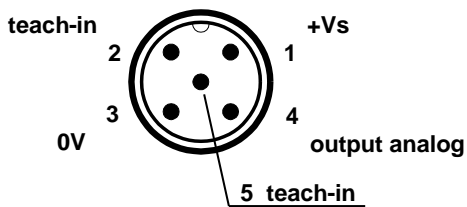

Dimensions (measurements in mm):

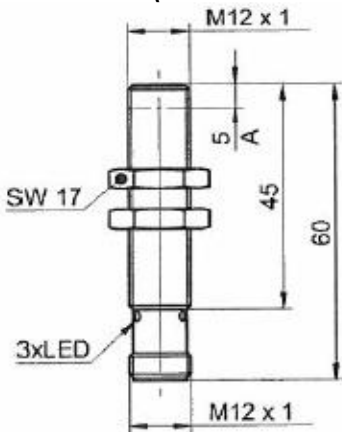

2. Setting the opening limiter (optional)

The valve has already been commissioned.

- Close the valve hydraulically according to separate valve instructions.
- Turn the set screw (12) downwards as far as it can go
- Set the required stroke and tighten the lock nut
- Check the flow rate and if necessary adjust the set screw.

Caution: The set screw must never be adjusted under pressure. The valve must be closed for re-adjustments of the stroke limitation. The set screw should always be well-greased.

Notes/ setting dimensions

3. Setting the sensor

The valve has already been commissioned.

Setting the switching distance:

- Close the valve hydraulically according to separate valve instructions. Slightly loosen the threaded pin (9) on the retaining collar (8) and then push the retaining collar with sensor until the sensor is aligned with the top edge of the display spindle(see drawing on page 3).
- Tighten threaded pin (9).
- Slightly loosen the lock nut on the sensor and turn the sensor carefully as far as the stop on the cone.
- Unscrew the sensor approx. ¼ turn. The measuring distance is now approx. 0.2mm. Re-tighten the lock nut.

There are now three different teach stages. The stages are attained with the contact duration of the teach cable with Vs+:

- One point teach, hold teach cable on Vs+ for 2s, LED flashes at 1 Hz
- Two point teach, hold teach cable on Vs+ for 4s, LED flashes at 2 Hz
- To reset to the factory settings, hold teach cable on Vs+ for 6s, LED flashes at 4 Hz.

The two teach points are described in the following:

Setting the valve closed measuring point:

- The switching distance is set according to the point above.
- Hold teach cable (WY or GR) on Vs+ . The LED first flashes at approx. 1 Hz. For the “One point teach”. Hold teach cable again on Vs+ (for approx. 4s) until the LED flashes at 2 Hz (two point teach).
Remove the teach cable again..
- Briefly hold teach cable on Vs+ . (> 0.2s)
- Run valve to the maximum required opening stroke
- Briefly hold teach cable on Vs+ . (> 0.2s)
- The yellow LED briefly lights up
- Programming completed

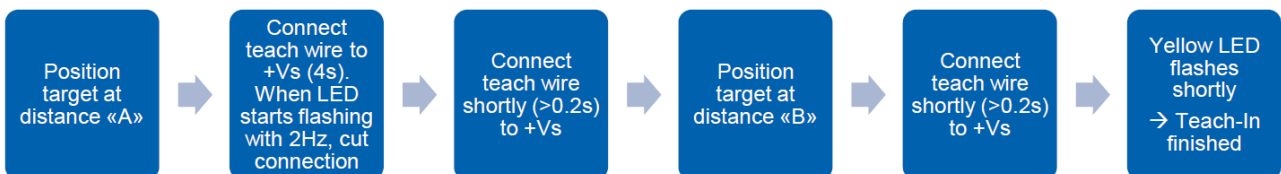
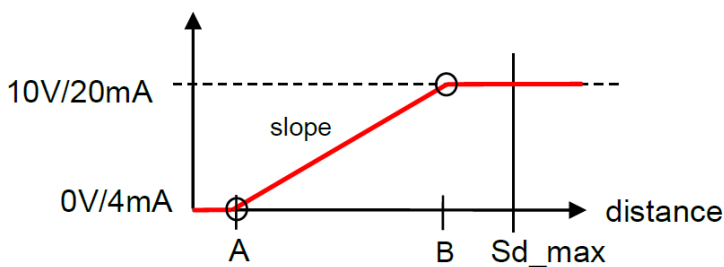

Caution: programming for the maximum stroke must take place within a minute. Otherwise the sensor returns to the previously programmed mode.

Resetting the sensor to the factory settings:

- Hold teach cable (WY or GR) on Vs+ . The LED first flashes with approx. 1 Hz. For the “One point teach”. After approx. 4 s the LED flashes with approx. 2 Hz (two point Teach). After 6 s the LED flashes at 4 Hz.
- Remove teach cable.
- The yellow LED briefly lights up
- The sensor is reset to the factory settings

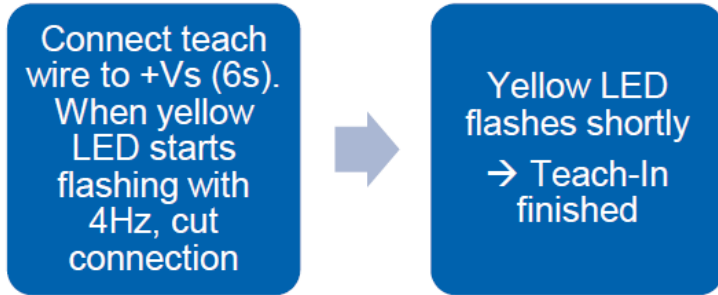

4. Troubleshooting

Symptoms	Possible cause	Action
No signalling when the valve is open or closed	Sensor maladjusted	Reset sensor
	Broken cable	Replace cable
Original flow values are not reached	Changed operating conditions	Regulate anew

Notes:

D. Maintenance and replacement parts

1. Maintenance

The analogue position indicator requires no special maintenance. When overhauling the valve (every five years), the o-rings and the compound seal must be replaced in accordance with the replacement parts list.

2. Spare parts

The article numbers can be seen in the replacement parts list. Always specify the serial number and year of manufacture of the valve when ordering spare parts!

2.1 Analogue position indicator (Drawing)

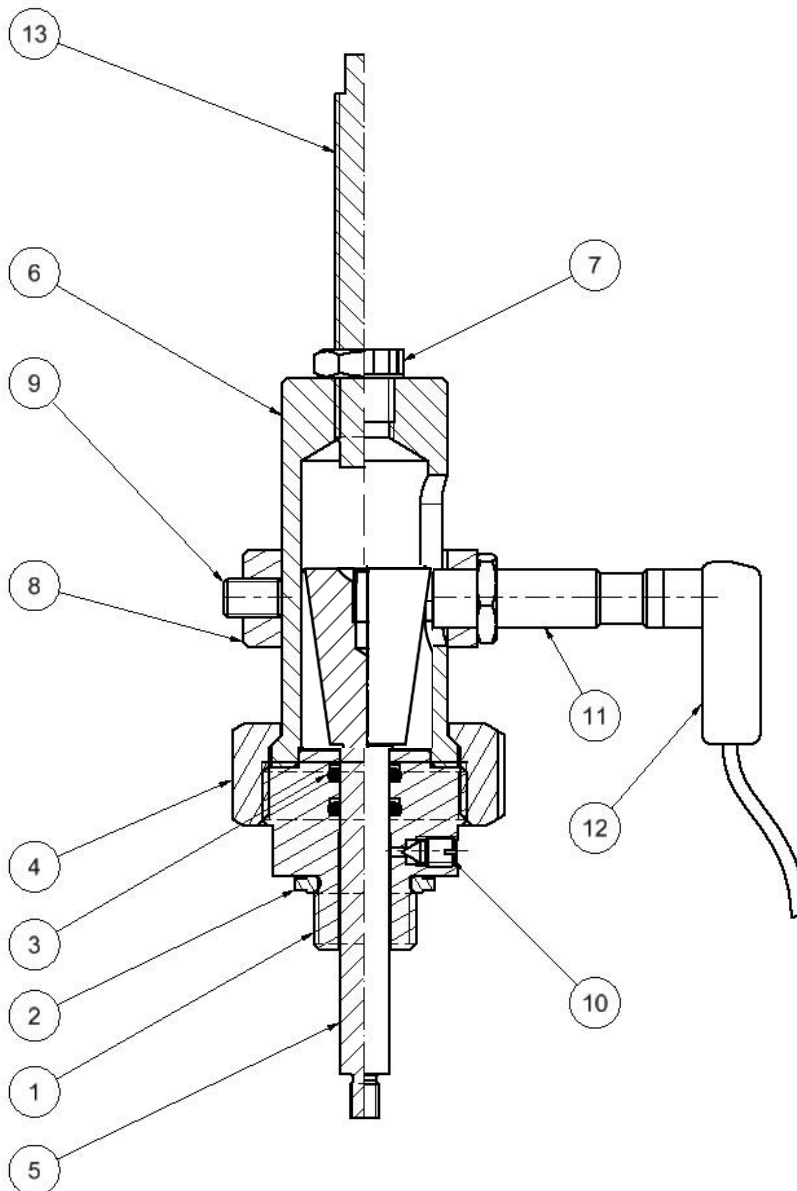

21.01.2016/mra

2.2 Analogue position indicator (Parts list)

Item	Description	Material	Article numbers		
			DN1 ½" ...DN50	DN65/100	DN125/200
1	Guide	Bronze	1999 800 100	1999 800 100	1999 800 200
2.	Compound seal	Stainless steel NBR	0130 016 000	0130 016 000	0130 025 000
3.	O-ring	EPDM	0170 009 926	0170 009 926	0170 013 926
4	Union nut	Stainless steel	1999 802 000	1999 802 000	1999 802 000
5	Display spindle complete	Stainless steel	1961 901 051	1961 901 101	1961 901 201
6	Body	Stainless steel	1961 902 101	1961 902 101	1961 902 201
7	Screw sockets	Plastic	0514 012 000	0514 012 000	0514 016 000
8	Retaining collar	Stainless steel	1961 900 000	1961 900 000	1961 900 000
9	Threaded pin	Stainless steel	0002 208 012	0002 208 012	0002 208 012
10	Threaded pin	Stainless steel	1999 804 000	1999 804 000	1999 804 000
11	Sensor 4 – 20mA	--	1961 903 011	1961 903 011	1961 903 011
	Sensor 0 – 10V		1961 903 021	1961 903 021	1961 903 021
12	Cable (to sensor)	--	1961 903 001	1961 903 001	1961 903 001
13	Opening limiter (optional)	Stainless steel	1999 806 100	1999 806 100	1999 806 200
	Analogue position indicator complete 4 to - 20mA		1960 000 001	1960 000 002	1960 000 003
	Analogue position indicator complete 0 to - 10mA		1961 000 001	1961 000 002	1961 000 003
	* to be replaced at an overhaul				

Item	Description	Material	Article numbers	
			DN250	DN300
1	Guide	Bronze	1999 800 300	1999 800 300
2.	Compound seal	Steel/NBR	0130 032 000	0130 032 000
3.	O-ring	EPDM	0170 013 926	0170 013 926
4	Union nut	Stainless steel	1999 802 000	1999 802 000
5	Display spindle complete	Stainless steel	1961 901 251	1961 901 301
6	Housing	Stainless steel	1961 902 301	1961 902 301
7	Cover	Plastic	0514 016 000	0514 016 000
8	Retaining collar	Stainless steel	1961 900 000	1961 900 000
9	Threaded pin	Stainless steel	0002 208 012	0002 208 012
10	Threaded pin	Stainless steel	1999 804 000	1999 804 000
11	Sensor 4 – 20mA	--	1961 903 011	1961 903 011
	Sensor 0 – 10V		1961 903 021	1961 903 021
12	Cable (to sensor)	--	1961 903 001	1961 903 001
	Analogue position indicator complete 4 to - 20mA		1960 000 004	1960 000 005
	Analogue position indicator complete 0 to - 10V		1961 000 004	1961 000 005
	* to be replaced at an overhaul			

E. Hawle in Europe

Addresses:

Hawle Armaturen AG
Hawlestrasse 1
CH-8370 Sirnach
www.hawle.ch

telephone +41 (0)71 969 44 22
fax +41 (0)71 969 44 11

Hawle Armaturen GmbH
Liegnitzer Strasse 6
D-83395 Freilassing
www.hawle.de

telephone +49 (0)8654 63 03 - 0
fax +49 (0)8654 63 03 60

E. Hawle Armaturenwerke GmbH
Wagrainerstr. 13
A-4840 Vöcklabruck
www.hawle.at

telephone +43 (0)76 72/72 576 0
fax +43 (0)76 72 78 464

Hawle Kft
Dobogókoi út 5
H-2000 Szentendre
www.hawle.hu

telephone +36 (0) 26 501 501
fax +36 (0) 26 501 502

Hawle Armatury spol. s r.o.
Ricanská 375
CZ-25242 Jesenice u.Prahy
www.hawle.cz

telephone +420 (0)2 410 03 111
fax +420 (0)2 41 00 33 33

Hawle Spółka zo.o
ul. Piaskowa 9
PL-62-028 Kozięglowy
www.hawle.pl

telephone +48 (0)61 811 14 00
fax +48 (0)61 811 14 27

Hawle s.r.o.
Pezinská c.30
SK-903 01 Senec
www.hawle.sk

telephone +421 (0)2 45 92 21 87
fax +421 (0)2 45 92 21 88

S.C. Hawle S.R.L.
Calea Sagalui 104
RO-300516 Timisoara
www.hawle.ro

telephone +40 268 47 78 81
fax +40 356 80 06 68

DM Armaturen EOOD
Ul. Lokomotiv 3
BG-1220 Sofia
www.hawle.bg

telephone +359 (0)2 931 12 77
Fax +359 2 931 04 36

Partners / Contact addresses:

28.07.2014-1/plü